



# Anchorage Water & Wastewater Utility

## Customer Service Division



### Fire Hydrant Use Requirements

Anchorage Water Utility (Utility), requires all customers seeking to use a fire hydrant to first obtain a hydrant use permit and a mobile meter. Pursuant to AWU Tariff Rule 15.5, all water taken from designated fire hydrants must be paid for, and all water that is recorded on the meter will be considered **usage from Utility Red Top hydrants**.

Fire hydrants designated as "Red Tops" are the only hydrants available for temporary construction service; refer to the [Red Top Hydrant list and map\(s\)](#) for locations. Use of a fire hydrant that is not on the Red Top list will result in fines per Anchorage Municipal Code (AMC) 26.40.040 and possible revocation of your hydrant meter and hydrant use permit. To obtain instructions for the proper operation of a fire hydrant, please contact our office at 564-2762.

A **1½ inch gate valve** in the fill line **is required** to protect the integrity of the Utility's distribution system and reduce the likelihood of damage to the meter. All meters are required to be mounted **horizontally** with the water flowing into the strainer first.

**Meter installations must be inspected by Utility personnel to ensure proper installation of the meter, within 10 business days of issuance. A valid permit will be issued upon successful inspection.** Failure to have the meter inspected could result in fines up to \$1,000 per AMC 26.40.040.

Payment of a security deposit is required before a hydrant meter will be issued. This deposit is refundable twenty-five (25) days after the return of the meter. **Damage to meters will be the responsibility of the permit holder and the repair costs will be deducted from deposits before any refunds are issued.**

**Meter size will be determined based on the size of the water tank.**

- Deposits for meters (required at time of application):
  - 1" meter - **\$303**
  - 1½" meter - **\$621**
  - 2" meter - **\$1,533**

**Billing will start from the day the meter is picked up.**

- Permit Fee: **\$77.00** per meter per season (will be posted to your first bill)
- Meter Size Charge:
  - 1" meter - **\$10.78**
  - 1½" meter - **\$1.57**
  - 2" meter - **\$34.50**
- Customer Charge: **\$10.53**
- Volume Rate: **\$6.91** per 1,000 gallons
- Regulatory Cost Charge (RCC): **0.690%** of billing

The recurring monthly bill will consist of the Meter Size Charge, Customer Charge, and RCC. All water consumption charges will be billed after meters are returned, or when the meter is presented to the Utility for a meter reading.

**All summer hydrant use permits expire on October 1<sup>st</sup> of the year issued.  
All winter hydrant use permits expire on May 1<sup>st</sup>.**

If you have additional questions, please call 564-2762, Monday through Friday, 8:00 am - 5:00 pm

Anchorage Water & Wastewater Utility  Clearly

3000 Arctic Boulevard • Anchorage, Alaska 99503  
Phone 907-564-2700 • Fax 907-562-0702 • Toll Free (866) 650-2700  
www.awwu.biz



## APPROVED METHODS OF INSTALLING METER ASSEMBLIES ON WATER TANKERS

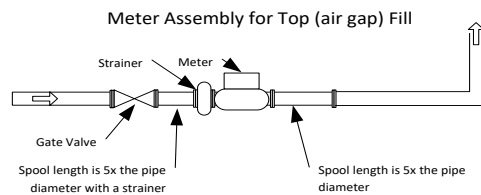
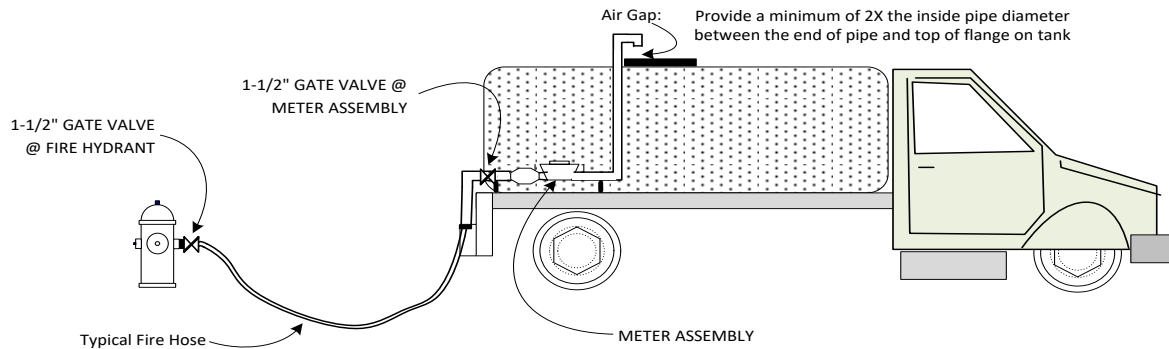

**NOTE: FAILURE TO USE AN APPROVED FIRE HYDRANT WRENCH ON ANY FIRE HYDRANT WILL RESULT IN A MINIMUM FINE OF \$150.00**

- \* ALL TANKERS SHALL HAVE A WATER METER MOUNTED ***HORIZONTALLY*** AT EXPENSE OF OWNER. THE METER SHALL BE ISSUED AND INSPECTED BY AWWU.
- \* THE METER SHALL BE INSTALLED WITH A ***1-1/2" GATE VALVE AND STRAINER BEFORE THE METER. BALL VALVES OR ANY OTHER "QUICK ON" TYPE VALVES WILL NOT BE PERMITTED.***
- \* TANKERS SHALL HAVE AN AIR GAP BETWEEN THE FILL LINE NOZZLE AND TOP HATCH. AIR GAP SHOULD EQUAL 2 TIMES THE DIAMETER OF THE FILL PIPE.
- \* THE CUSTOMER SHALL MAKE EVERY EFFORT TO PROTECT THE METER FROM PHYSICAL ABUSE, SUDDEN AIR AND WATER FLOWS, AND FREEZING. DAMAGED METERS SHALL BE REPLACED OR REPAIRED AT CUSTOMER EXPENSE.
- \* ANY TRUCK THAT UTILIZES A DUAL WATER FILL SYSTEM SHALL HAVE A SEPARATE CONNECTION COUPLING.

**NOTE: TO AVOID BEING CHARGED FOR THE HYDRANT METER, ALL HYDRANT METERS ARE TO BE RETURNED WITHIN 2 WEEKS AFTER HYDRANTS HAVE CLOSED FOR EITHER THE SUMMER OR WINTER SEASON.**