



### 3" or Larger Meter with By-Pass Installation Guidelines

1. Standard water meter installations shall adhere to the current edition of the AWWU Design and Construction Practices Manual (DCPM), Uniform Plumbing Code (UPC), and guidelines outlined in the American Water Works Association (AWWA) manuals.
2. Water meter installation is mandatory for all residential structures comprising four units or more and for all commercial buildings. Metering remains optional for duplexes and triplexes. The installation of irrigation meters necessitates prior approval from an AWWU Field Service supervisor.
3. The determination of appropriate meter size for multi-family residential and commercial buildings shall be conducted by an AWWU Field Service supervisor.
4. For manufactured structures such as mobile offices or buildings, meters must be installed above the finished floor inside the building, refraining from placement in the 'skirted' area beneath the structure.
5. Meter installation must align with best plumbing practices, ensuring:
  - a) Placement in a designated area solely allocated for the meter, valves, and check valve assemblies, **with all other plumbing apparatus installed after the last valve on the downstream side of the meter.**
  - b) **Horizontal positioning prior to any branched services.**
  - c) Installation in a dry, frost-proof, and easily accessible open area free from concealment or obstruction by appliances, heaters, building materials, or storage items.
  - d) Adequate clearance on all sides and above the floor, as per attached Meter Assembly details.
  - e) Height not exceeding forty-two (42) inches without an approved platform.
6. Belowground installation of meters in a pit or pit environment is prohibited.
7. Installation of meters in a crawl space is permissible under the following conditions:
  - a) The depth of the crawl space, measured vertically from the ground to the bottom of the floor joists, must be forty (40) inches.
  - b) The crawl space must be illuminated and equipped with a permanently secured ladder.
  - c) The meter assembly must be within ten (10) feet of the crawl space opening, with unobstructed access, such as heating vents or support walls.
  - d) The entry to the crawl space shall be a minimum of twenty-four (24) inches by thirty (30) inches, with unblocked and unobstructed access.
8. Failure to install meters within 30 days of issuance will result in their return to AWWU.
9. If the meter is not within 10 feet of an outside wall, conduit provision for remote reading wire is required for new constructions.
10. Special Instructions:
  - a) There shall be a minimum or 3X the pipe diameter clearance around the meter and all appurtenances shown in these details.
  - b) All pipes and appurtenances shall be properly supported and supports shall not interfere with removal of the meter.
  - c) There shall be no piping, duct work or any other obstructions directly in the front of the meter.

- d) There shall be no electrical grounding (jumper) wires touching any part of the meter or meter assembly. If required, jumper wires shall be connected to pipes upstream and downstream of the valves. There shall be no jumper wire between the valves or directly connected to the meter, spools, or backflow assemblies. Provide a minimum of two (2) inches of clearance between the jumper wire and any part of the meter.
- e) When adding a meter to existing plumbing, an expansion tank may be necessary upstream of the meter.

To schedule a pre-meter installation meeting if the conditions cannot be met, contact AWWU at 564-2700. Following installation, call 564-2700 to arrange for a meter inspection. A minimum of twenty-four (24) hours' advance notice is mandatory for scheduling inspections.

Customers will incur a return visit inspection fee in the event of a failed meter inspection.

**\*\* All meters provided by AWWU are the sole property of the Utility and must not be disposed of under any circumstances. Meters that are no longer required or in use should be promptly returned to AWWU Customer Service. In the event of damage, loss, or theft, whether resulting from neglect or other causes, the responsible party will be liable for the replacement cost of the meter.\*\***

**3" or Larger Disc / Turbine / Compound Meter Assembly Require a By-Pass (Front View)**

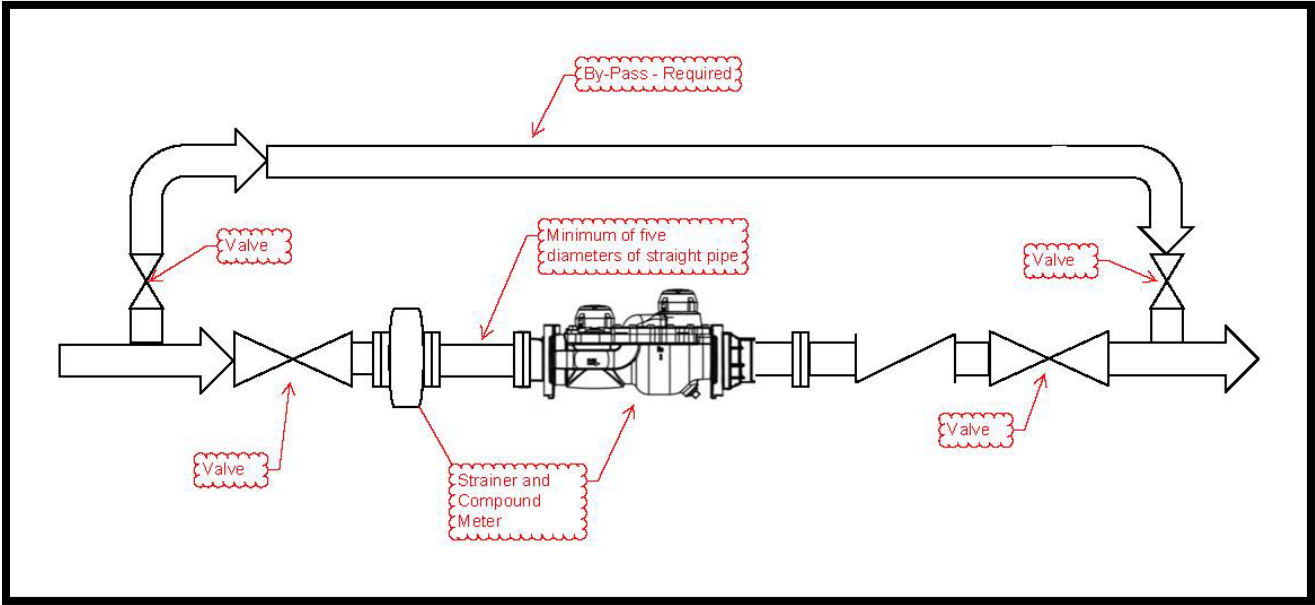

**For a larger, detailed drawing, please visit:**

[www.AWWU.biz](http://www.AWWU.biz) / Customer Service / In the Field / Meter Installation and Maintenance

